



Photo courtesy: Samaritan's Purse



Product catalogue





Click pages to navigate



Contents



4 Our Mission and Vision



5 Our Perspective



6 Innovation & Sustainability



7 Family Tents

8 DomeHome self-standing family tent **NEW**

9 GeoHome Family Tent **NEW**

10 Cradle Tent **NEW**

11 Viva Family Tent FR **NEW**

12 Viva Family Tent **NEW**

13 Viva Family Framed Tent **NEW**

Add-ons

14 Viva Winterization Kit

15 Winterization Kit for GeoHome



16 Multipurpose Tents

17 Legend 33 Tent

18 Legend 45 Tent

19 LegendMEDI **NEW**

20 Huggy Pro - HPT 24 **NEW**

21 Huggy Pro - HPT 48 **NEW**

22 Huggy Pro - HPT 72 **NEW**

23 Huggy 24

24 Huggy 42

25 Huggy 72

26 Dispensary Tent

Add-ons

27 Inner Liner **NEW**

28 Winter Liner **NEW**

29 Hard Flooring **NEW**

30 Solar Lighting Kit **NEW**

31 Electrical Lighting Kit **NEW**



32 Mobile Storage Units

33 Rex Hall MSU 6.5 x 8 m

34 Rex Hall MSU 10 x 24 m

35 Rex Hall MSU 10 x 32 m

Add-ons

36 LED Lighting Kit

Ballast Anchors

Flexible Flooring System

Hard Flooring System

Fire Alarm system

Mechanical ventilation

Windows

Pedestrian Doors

Lateral Linking Kit

Solar Energy Systems



37 Core Relief Items

38 Woven Flexible Tarpaulin

39 Reinforced Plastic Tarpaulin

40 Coverage Kit

41 Viva Stove

42 Aquatainer 10L Collapsible

44 Aquatainer 20L Collapsible

45 Synthetic Sleeping Mat

46 Multipurpose Sleeping Mat **NEW**

47 Viva Thermal Sleeping Mat

48 Pura Water Bucket

49 Jerry Bucket

50 Low Thermal Synthetic Blanket

51 Medium Thermal Synthetic Blanket

52 High Thermal Synthetic Blanket

We
design, develop
and **deliver**
value-engineered
solutions to the
humanitarian sector.





Our mission

NRS Relief is a purpose-driven company that designs, develops and delivers value-engineered solutions to the humanitarian sector. We create life-improving products in partnership with our clients, such as UN Agencies, International Organizations and NGOs worldwide.

We supply relief essentials, shelter solutions, multipurpose tents and mobile storage units, as well as customized products and services.

Our vision

Central to our approach to business is the thorough understanding of the purpose of the work carried out by our clients. We align our business capabilities with the goals and needs of humanitarian and development actors, who respond to pressing issues such as forced displacement and natural disasters. Our vision is to provide essential solutions to all actors responding to humanitarian crises, aimed at meaningfully impacting the lives of the affected people. By doing so, we ensure sustainable economic empowerment of the local community in Pakistan through the strategic partnership with our manufacturing arm.

Shelter is far more than a roof and four walls

Shelter is a basic human need and is critical for survival in most disasters. At NRS Relief, we have developed shelter solutions for over 45 years, supplying refugee tents, multipurpose shelters, mobile storage units and core relief items, i.e. tarpaulins and blankets to UN agencies, international NGOs and bilateral donors. Our aim is to offer cost-effective, fit-for-purpose quality shelters and aid essentials, keeping the real needs of the beneficiaries in mind.



Our perspective



Shelter is a basic human right



Protect dignity; quality counts



Durability and cost-effective solutions



Continuous product innovation



Understanding local environment and beneficiaries' needs



Promote recycling and sustainability

Innovation & Sustainability



We believe that sustainable business makes smart business. For us, embracing a sustainable humanitarian supply chain is a way of honoring our purpose as a relief supplier. We see purpose-driven sustainability as our contribution towards social, environmental as well as economic progress.

Economic responsibilities

We are committed to pioneering new solutions, sustainably creating fit-for-purpose products through value-engineering. We focus on financial sustainability and pledge to continuously expand our portfolio of products and services. At the same time, as the industry leader we strive to progressively grow our business to ensure economic empowerment in our supply chain. Our vision is that all stakeholders should benefit from the life-improving products that we develop and design - from factory to the field.

Social responsibilities

We focus on creating a safe, diverse, merit-based working environment that values teamwork yet allows for individual growth. We actively engage with the vibrant humanitarian community in Dubai and raise awareness for social causes such as the refugee crisis and women's empowerment. At the same time, we support our manufacturing arm

in Pakistan with their community investment programs, aimed at building community resilience through improved health care services and educational opportunities. We also acknowledge the social impact of our products on the end-user – from refugee to aid worker. To honor this purpose, we develop and design products that respect beneficiaries' true needs and support the acceleration of the sustainable development goals.

Environmental responsibilities

Minimizing our ecological footprint is an incentive rather than a burdensome exercise in compliance. We are committed to reducing emissions and waste, while seeking to recycle and reuse across the production processes wherever possible. We do so in close collaboration with our manufacturing arm as well as by launching green initiatives in our Dubai office and offices in Lahore.

As a manufacturer we have always been very conscious about material sourcing and optimal material use, and energy and water usage in our operations, as this has a direct impact on the operational costs and competitive position of the products we sell. In the last years we have made significant reductions in the energy and water usage in our operations with a greater focus on improving our sustainability performance. We are also working closely with our suppliers in order to reduce the carbon footprint of the materials we use. We are constantly researching production processes and material sources including the use of recycled materials and reduction of single use plastics. As a result, we initiated a project aiming at reducing the environmental impact and the carbon footprint of relief items, i.e. tarpaulins, blankets, jerrycans and buckets, targeting a 40% reduction in carbon emissions.

Family Tents

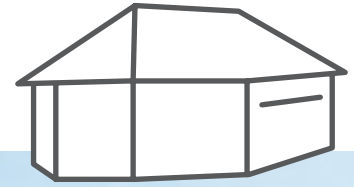

Our fire-retardant family tents are fit-for-purpose, durable shelters designed for humanitarian settings. All our tents comply with recommended minimum living area in hot and moderate climates (3.5 m² per person), providing extra space for cold climates. We offer a new-generation of polyethylene self-standing tents and the classic poly-cotton family shelter.

In cold climate a winterization kit can be used to add an extra layer of protection against cold, wind and snow.

DomeHome self-standing family tent

UNHCR Standard

Fire retardant
Lightweight
Waterproof
Rot-proof
UV stabilized
Logo customizable
NEW



› Key features

- › New generation dome-shaped self-standing family tent
- › 3-layers: outer tent, pre-fitted inner tent and shade cover
- › PE fabric, lightweight and strong
- › Interior allows standing in all corners for maximum space
- › Adaptable to all climates. advanced ventilation
- › Easy set-up (less than 30 minutes, 3 persons)
- › UV resistance, FR and waterproof
- › Durable and recyclable materials
- › Accommodates five persons
- › Rapid deployment in any emergency

› Dimensions

Total living area	18.5 m ²
Centre height	2.40 m
Length	4.30 m
Width	4.30 m
Entrance wall height	1.90 m
Door height	1.70 m

› Materials

Outer tent (roof, walls, mud flaps, partition, groundsheets)	190 ±10% g/m ² Polyethylene fabrics. Woven high-density polyethylene (HDPE) black film, coated with low-density polyethylene (LDPE) on both sides. Fire retardant under EN 13823 + A1 and CPAI84
Inner	150 ±15% g/m ² Poly-cotton blend fabrics Fire retardant under CPAI84
Mosquito net (doors, windows, ventilation)	85-100 g/m ² 100% Polyester, warpknitted 25 holes/cm ²

› Graphic reference

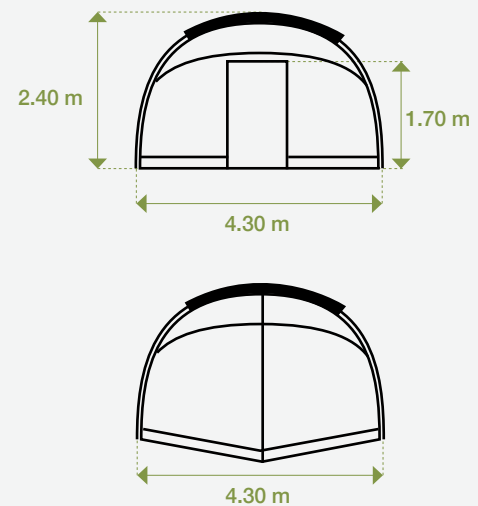

GeoHome Family Tent

ICRC/IFRC/IOM Standard

- Fire retardant
- Waterproof
- Rot-proof
- UV stabilized
- Logo customizable



› Key features

- › New generation family tent, geodesic shape for more beneficiary comfort and safety
- › Two-layer: outer tent and shade cover
- › Fire retardant, waterproof and UV resistant
- › Adaptable to all seasons. Optional inner liner and winter modules available
- › Accommodates a family of five people
- › Quick set-up, three persons in 30 minutes
- › Can withstand wind loads up to 120 km/ph
- › Rapid deployment in any emergency on pallets or in cages

› Dimensions

Total living area	19.6 m ²
Centre height	2.40 m
Length	4.33 m
Width	5.58 m
Door height	1.70 m

› Materials

Outer tent (roof, walls, mud flaps, partition, groundsheets and shade fly)	Base fabric: Woven high-density polyethylene (HDPE) black fibres Coating: white low density polyethylene (LDPE) on both sides, 190 gsm Fire retardancy: EN13823+AI
Mosquito nets	Polyester. Outer tent: 7-9 holes per inch ² . Inner tent: 20-25 holes per inch ²
Frame	All aluminium Main pipes: outer diameter 19 mm ±0.5 mm, thickness 1.2 mm ±1%, Connectors: outer diameter adapted to main pipe, thickness 1.5 mm ±1%

› Graphic reference

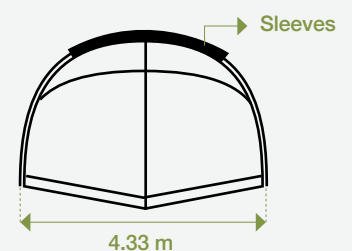
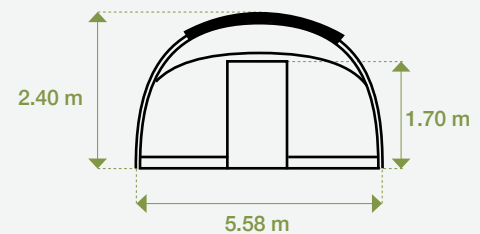

Cradle Tent

Developed with UNHRD Lab

- Fire retardant
- Waterproof
- Rot-proof
- UV stabilized
- Eco friendly



Cradle cover glowing in the dark

› Key features

- › New generation family tent, geodesic shape
- › 3-layer: Outer tent, inner tent and shade cover
- › Adaptable to all climates
- › Easy-setup (30 minutes, 3 persons)
- › UV resistance, FR and waterproof
- › Rapid deployment in any emergency
- › This product has been developed with a focus on end-to-end sustainability as the family tent is provided with a box designed to be used as a cradle for babies including accessories made using upcycled materials

› Dimensions

Total living area	19.6 m ²
Centre height	2.40 m
Length	4.33 m
Width	5.58 m
Wall height	Dome-shaped
Door height	1.80 m (1.7 m inner tent)

› Materials

Outer tent (roof, walls, mud flaps, partition, groundsheets and shade fly)	Base fabric: Woven high-density polyethylene (HDPE) black fibres Coating: White low density polyethylene (LDPE) on both sides, 190 gsm. Fire retardancy: EN13823+A1
Inner tent	Polycotton, White, 125 gsm ±5%
Mosquito nets	Polyester. Outer tent: 7-9 holes per inch ² . Inner tent: 20-25 holes per inch ²
Frame	All aluminium main pipes: outer diameter 19 mm ±0.5 mm, thickness 1.2 mm ±1% Connectors: outer diameter adapted to main pipe, thickness 1.5 mm ±1%

› Graphic reference

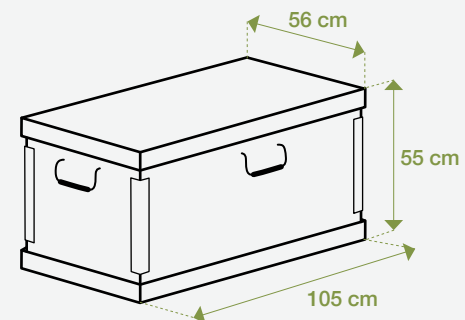
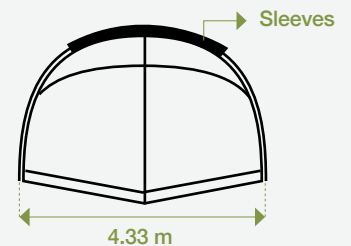

Viva Family Tent

UNHCR Standard

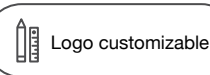
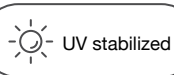
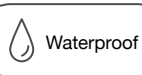
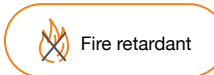

› Key features

- › Fire retardant, waterproof, rotproof and UV-stabilised
- › 16 m² main floor area plus two 3.5 m² vestibules for a total area of 23 m², double-fly with ground sheet
- › Complies to recommended minimum living area in hot and temperate climates (3.5 m² per person), providing extra space for cold climates
- › Suitable for family of five people

› Dimensions

Total living area	23 m ²
Main floor	16 m ²
Two vestibule area	3.5 m ² x 2 = 7 m ²
Centre height	2.20 m
Width	4.00 m
Ridge length	4.00 m
Side wall height	1.25 m
Centre base length	6.60 m

Tent doors (width and height)

Total size	1.30 x 1.40 m
Door flaps	1.40 x 1.60 m
Upper part	1.40 x 0.90 m (PC)
Lower part	1.40 x 0.70 m (PE)

Upright poles

2 Upright poles	2.20 m
1 Centre upright pole	2.17 m
Pole diameter	25 x 1.20 m

Side poles

6 Side poles	1.25 m
4 door poles	1.40 m
Pole diameter	19 x 1.25 m

› Graphic reference

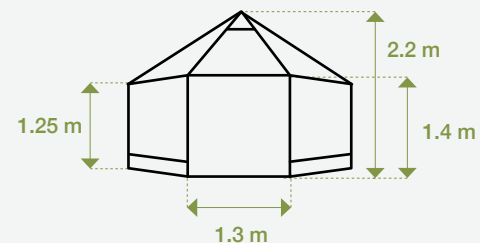
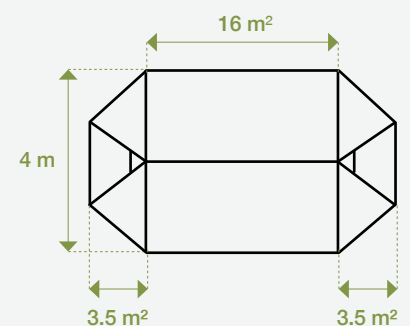

Viva Family Tent

ICRC/IFRC Standard

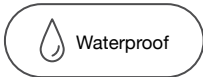

Waterproof



Rot-proof

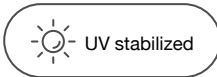

UV stabilized

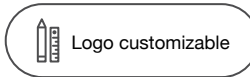

Logo customizable



› Key features

- › Waterproof, rotproof and UV-stabilised
- › 16 m² main floor area plus two 3.5 m² vestibules
- › Large windows (360 cm wide and 60 cm high)
- › Minimum living area in hot and temperate climates
- › Suitable for family of 5 people

› Dimensions

Total living area	23 m ²
Main floor	16 m ²
Two vestibule area	3.5 m ² x 2 = 7 m ²
Centre height	2.20 m
Width	4.00 m
Ridge length	4.00 m
Side wall height	1.25 m
Centre base length	6.60 m

Tent doors (width and height)

Total size	1.30 x 1.40 m
Door flaps	1.40 x 1.60 m
Upper part	1.40 x 0.90 m (PC)
Lower part	1.40 x 0.70 m (PE)

Upright poles

2 Upright poles	2.20 m
1 Centre upright pole	2.17 m
Pole diameter	25 x 1.20 m

Side poles



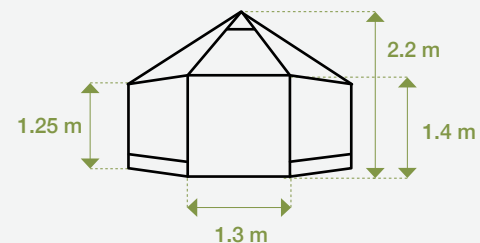
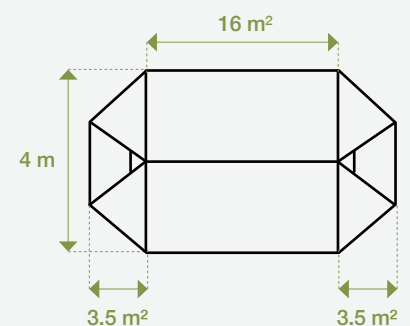

6 Side poles	1.25 m
4 door poles	1.40 m
Pole diameter	19 x 1.25 m

› Graphic reference



Viva Family Frame Tent

ICRC/IFRC Standard

-  Easy to set up
-  Waterproof
-  Rot-proof
-  UV stabilized
-  Logo customizable



› Key features

- › Waterproof, rotproof and UV-stabilised
- › Easy to set up and to erect in fewer surface
- › The symmetric flaps offer the possibility to join two tents together lengthwise to create larger units
- › Fit for emergency situations, in all climates
- › Suitable for family of 5 people

› Dimensions

Centre height	2.4 m
Width	4.15 m
Ridge length	4 m
Side wall height	1.50 m
Door height	1.6 m
Centre base length	5.2 m

Front doors (width and height)

Size	1.5 x 1.5 m
Door flaps	1.5 x 1.6 m
Upper part	1.5 x 1.08 m (made of canvas)
Lower part	1.5 x 0.52 m (made of woven PE)

Rear doors (width and height)

Size	1.0 x 2.1 m
Door flaps	1.0 x 2.1 m
Upper part	1.0 x 1.58 m (made of canvas)
Lower part	1.0 x 0.52 m (made of woven PE)

› Graphic reference

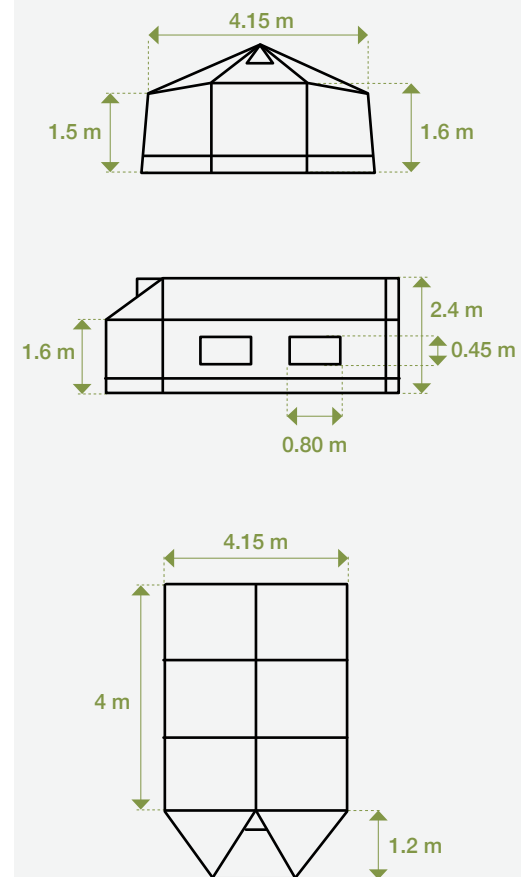

Viva Winterization Kit

ICRC/IFRC Standard



› Key features

- › Specially designed for [Viva Family Tents](#) to improve the insulation against cold climates
- › The kit includes the following items:
 - 5 insulated sleeping mats
 - 1 winterization liner
 - 1 partition
 - 1 heat-resistant floor protection (for stove) and
 - 1 heat-resistant chimney sleeve
- › All components are fire retardant to the level of CPAI84 regulation
- › All materials and additives are non-toxic, free from asbestos and other toxic products according to the EC regulations
- › Individually packed in a strong, waterproof plastic bag made of standard plastic tarpaulin
- › In case FR tent is used, no partition in the kit is to be supplied as the same is available in the tent itself

› Insulated flooring mats

Designed to protect families against cold from the ground or in any other floors during cold weather

Dimensions	1.8 x 0.9 m per mat
1st layer, plastic floor mat	Tight woven twill structure, double thickness, virgin PP multifilament 500 deniers in warp, minimum 1,000 tubes/meter, 500 gsm minimum weight
2nd layer, alumnized canvas	Synthetic canvas with durable aluminium coating
3rd layer, fleece blanket	Refer to our Medium Thermal Synthetic Blanket
Design	Heavy-duty ribbon strongly stitched all around the mat

› Graphic reference

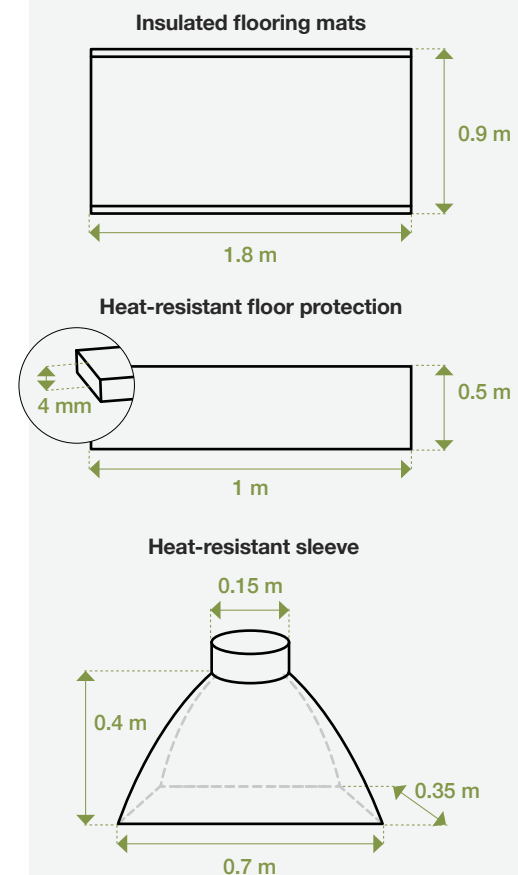

Winterization Kit for GeoHome

- Fire retardant
- Waterproof
- UV stabilized
- Snow and wind protection



› Key features

- › Specifically designed to winterize GeoHome, the geodesic family tent ICRC/IFRC/IOM specifications
- › An insulated winter cover to be placed directly over the family tent to keep the warmth inside and prevent heat loss
- › An extra layer of protection against cold, wind and snow
- › Fire retardant, waterproof and UV resistant
- › Including fireproof chimney patch and flue pipe sleeves for the placement of the stove inside the tent
- › Adding 8.4 m² space in its front and back vestibules areas
- › Quick set-up, 3 people in 20 minutes
- › Rapid deployment in any emergency on pallets or in cages

› Dimensions

Total living area	27.00 m ²
Total vestibule area	8.40 m ²
Centre height	2.40 m
Length	7.73 m
Width	5.58 m
Door width and height	1.60 x 1.65 m

› Materials

Winter cover (roof, walls, snow flaps)	Base fabric: Woven high-density polyethylene (HDPE) black fibers, Coating: white low-density polyethylene (LDPE) on both sides, 190 gsm, Fire retardancy: EN13823+AI
Window cover	Polyester mesh, 20-25 holes per inch ²
Chimney patch and sleeve	Fireproof glassfiber fabric
Frame	Door frames: Steel, galvanized, 19 mm Ø, 1 mm wall thickness Ridge pole: Steel, galvanised, 25 mm Ø, 1 mm wall thickness Upright poles: steel, galvanized, 25 mm Ø, 1.2 mm wall thickness

› Graphic reference

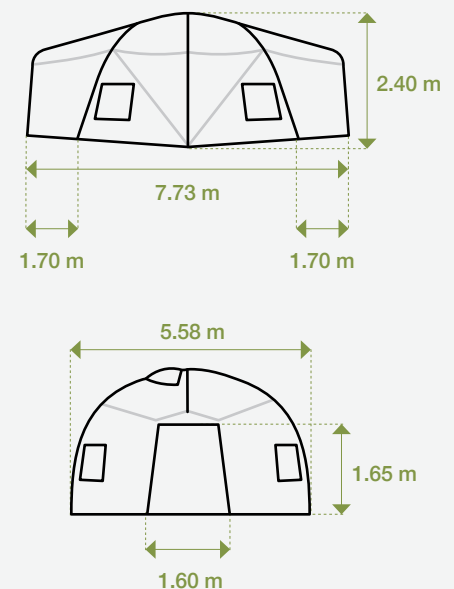

Multipurpose Tents



Our multipurpose tents are essential tools during emergency response and humanitarian programs. The tents can be used for various applications such as medical and office space, as a school or to provide accommodation. With the optional add-ons, like liners and lightings kits and flooring, the multipurpose tents can be customized to meet any need.

New to the range are the HuggyPro - HPT tents, which combine many of the often requested requirements into a sustainable solution.



Legend 33 Tent

ICRC/IFRC Standard



Fire retardant (optional)



Waterproof



Rot-proof



UV stabilized



Logo customizable



› Key features

- › Multipurpose tent which can be used for schooling, office, clinic, health centre, storage or temporary shelter purposes and can be attached to one another to make a longer structure
- › Separate ground sheet for use in tent is available as option in case main tent is used for living conditions / clinics
- › For hot climates shade net with frame is also available as option
- › For increase protection from heat, cold, wind, dust, and insects an Inner tent with sewed in bath tub type ground sheet is available as an option
- › Suitable for 15-30 persons

› Dimensions

Outer tent

Total size	6 x 5.62 m
Ridge height	3.00 m
Side wall height	2.10 m

Inner tent

Total size	5.70 x 5.33 m
Ridge height	2.80 m
Side wall height	1.95 m

› Materials

Outer tent	Roof, wall fabric: Poly-Cotton blended fiber yarns, 310 gsm - 315 gsm, 320 gsm in finished state for the walls
Mud flaps	PVC coated fabric polyester 1100 dtex, PVC coated 2 sides 540 gsm

› Graphic reference

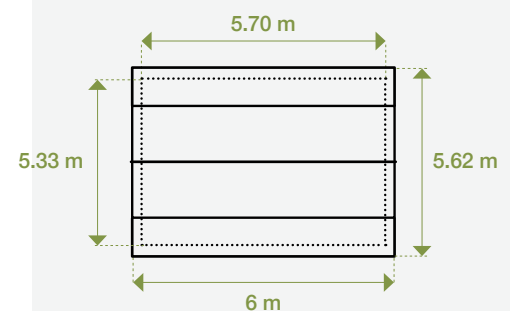
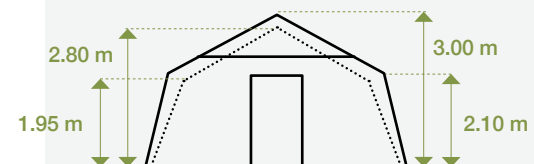

— Outer tent
 Inner tent



Legend 45 Tent

MSF/ICRC/IFRC Standard



Fire retardant (optional)



Waterproof



Rot-proof



UV stabilized



Logo customizable



› Key features

- › Multipurpose tent which can be used for schooling, office, clinic, health center, storage or temporary shelter purposes and can be attached to one another to make a longer structure
- › Separate ground sheet for use in tent is available as option in case main tent is used for living conditions / clinics
- › A shade net is available as an optional accessories in hot climates
- › Set of 5 partitions to create separate areas and a closed cabin inside the tent is available as option
- › For increase protection from heat, cold, wind, dust, and insects an Inner tent with sewed in bath tube type ground sheet is available as an option
- › Suitable for 20-40 person

› Dimensions

Outer tent

Total size	7.50 x 6.00 m
Ridge height	3.00 m
Side wall height	2.10 m

Inner tent

Total size	7.20 x 5.70 m
Ridge height	2.80 m
Side wall height	1.95 m

› Materials

Outer tent	Roof, wall: Poly-Cotton blended fiber yarns, 440 gsm for the roof, 320gsm in finished state for the walls
Mud flaps	PVC coated fabric polyester 1100 dtex, PVC coated 2 sides 540 gsm

› Graphic reference

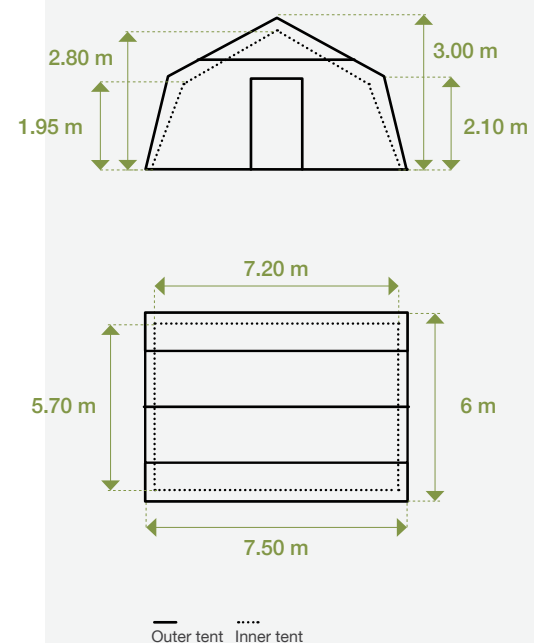

LegendMEDI

MSF Standard

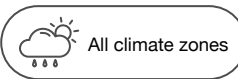
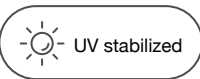
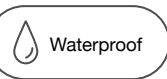
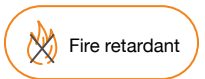

› Key features

- » This tent is designed in response to the Ebola epidemic in 2014. The medical tent can be deployed in case of haemorrhagic fever outbreaks such as Ebola and Lassa. Also, it can be deployed in cases of outbreaks of infectious diseases such as cholera
- » It offers solutions such as treatment and isolation rooms for both suspected and confirmed patients.
- » The individual cabins for suspected patients prevent cross-contamination between infected and healthy patients
- » The medical tent is constructed in a way no (infected) material can accumulate on the surface of the tent, in seams or other parts
- » The tent is designed to allow freedom of movement and easy operation like opening/closing of the doors with magnetic closures, wearing protective clothing
- » The special treatment cabins and other accessories are made of PVC coated polyester or polyethylene tarpaulin with non-corrosive accessories, whereby all seams and attachment points which might get in touch with patients, are heat or HF welded
- » All tent components can be disinfected with chlorine-based disinfectants or other commonly used detergents
- » It can be erected on various soil conditions and in different climate conditions, from moderate to tropical

› Dimensions

Cabin for confirmed patients	4.2 x 7.2 x 2 m = total floor space 30.2 m ² Door opening of 1.8 x 1 m
Cabin for suspected patients & Examination rooms - 4 cabins	2 cabins (2 rooms per cabin) 4.2 x 3.5 x 2 m = total floorspace 14.7 m ² Total floorspace 2 cabins (total 4 cabins) = 29.4 m ² Total floorspace per room = 7.3 m ²
Partition panels	2 x 2 m
Shade net	6.5 x 8 m
Canopy shade net	6.5 x 4 m

› Graphic reference

Cabin for **confirmed** patients



Main tent + Roof cover

Cabin for **suspected** patients - 4 cabins



Main tent with individual cabin

Examination cabin

Designed for examining patients by a doctor while family members can watch safely from behind the window.

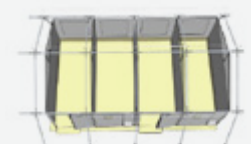



Huggy Pro - HPT 24

UNICEF standard

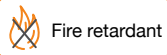

Fire retardant



Waterproof



Rot-proof



UV stabilized



All climate zones



› Key features

- › Huggy Pro - High Performance Multipurpose Tent made of high quality and durable materials, ensuring a strong construction
- › Solution is comprised of outer cover, shade net, groundsheet and partition
- › A spacious 24 m² tent with vertical walls for optimum use of inner space
- › Cost-efficient, lightweight and compact packing
- › Strong and lightweight high tensile steel frame structure to withstand high wind and snow loads
- › Rot and mildew proof, easy to clean and disinfect, resistant to commonly used disinfectants and detergents
- › High performing in hot, cold and wet weather conditions; does not 'heat up' in direct sunlight, blocks UV, does not break or absorb moisture in below zero temperatures
- › High comfort thanks to advanced ventilation and large mesh windows
- › Environmentally friendly: low energy production process, fully recyclable, safely disposable by burning or burying when recycling is not possible

› Dimensions

Total size	24 m ²
Floor size	6.0 x 4.0 m (±1%)
Central height outer tent	3.00 m (±1%)
Wall height outer tent	2.05 m (±1%)
Structure	Lightweight tubular steel frame structure
Window size	135 x 135 cm
Ventilation grates	135 x 20 cm

Add-ons

- › Inner liner
- › Winter liner with insulated flooring
- › Hard flooring
- › Electrical lighting kit
- › Solar lighting kit

› Graphic reference

Front view

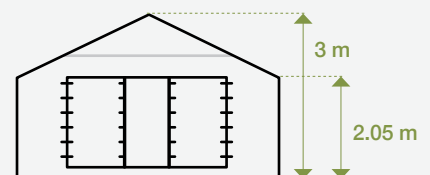

Side view (Window and ventilation)

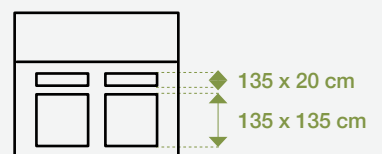

Top view

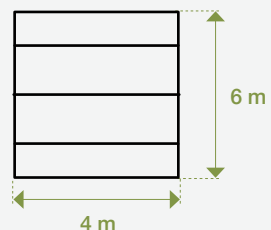



Huggy Pro - HPT 48

UNICEF standard



Fire retardant

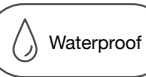

Waterproof



Rot-proof

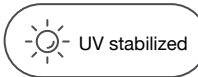

UV stabilized

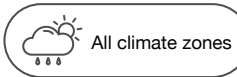

All climate zones



› Key features

- › Huggy Pro - High Performance Multipurpose Tent made of high quality and durable materials, ensuring a strong construction
- › Solution is comprised of outer cover, shade net, groundsheet and partition
- › A spacious 48 m² tent with vertical walls for optimum use of inner space
- › Cost-efficient, lightweight and compact packing
- › Strong and lightweight high tensile steel frame structure to withstand high wind and snow loads
- › Rot and mildew proof, easy to clean and disinfect, resistant to commonly used disinfectants and detergents
- › High performing in hot, cold and wet weather conditions; does not 'heat up' in direct sunlight, blocks UV, does not break or absorb moisture in below zero temperatures
- › High comfort thanks to advanced ventilation and large mesh windows
- › Environmentally friendly: low energy production process, fully recyclable, safely disposable by burning or burying when recycling is not possible

› Dimensions

Total size	48 m ²
Floor size	6.0 x 8.0 m (±1%)
Central height outer tent	3.00 m (±1%)
Wall height outer tent	2.05 m (±1%)
Structure	Lightweight tubular steel frame structure
Window size	135 x 135 cm
Ventilation grates	135 x 20 cm

Add-ons

- › Inner liner
- › Winter liner with insulated flooring
- › Hard flooring
- › Electrical lighting kit
- › Solar lighting kit

› Graphic reference

Front view

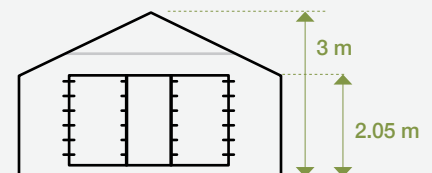

Side view (Window and ventilation)

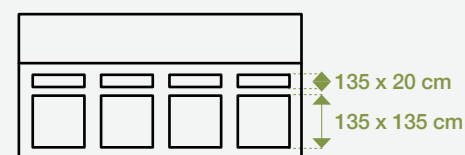

Top view





Huggy Pro - HPT 72

UNICEF standard

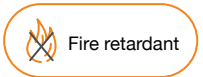

Fire retardant

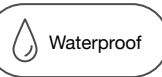

Waterproof



Rot-proof

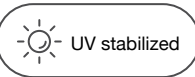

UV stabilized

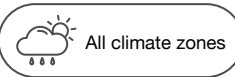

All climate zones

NEW

› Key features

- › Huggy Pro - High Performance Multipurpose Tent made of high quality and durable materials, ensuring a strong construction
- › Solution is comprised of outer cover, shade net, groundsheet and partition
- › A spacious 72 m² tent with vertical walls for optimum use of inner space
- › Cost-efficient, lightweight and compact packing
- › Strong and lightweight high tensile steel frame structure to withstand high wind and snow loads
- › Rot and mildew proof, easy to clean and disinfect, resistant to commonly used disinfectants and detergents
- › High performing in hot, cold and wet weather conditions; does not 'heat up' in direct sunlight, blocks UV, does not break or absorb moisture in below zero temperatures
- › High comfort thanks to advanced ventilation and large mesh windows
- › Environmentally friendly: low energy production process, fully recyclable, safely disposable by burning or burying when recycling is not possible

› Dimensions

Total size	72 m ²
Floor size	6.0 x 12.0 m (±1%)
Central height outer tent	3.00 m (±1%)
Wall height outer tent	2.05 m (±1%)
Structure	Lightweight tubular steel frame structure
Window size	135 x 135 cm
Ventilation grates	135 x 20 cm

Add-ons

- › Inner liner
- › Winter liner with insulated flooring
- › Hard flooring
- › Electrical lighting kit
- › Solar lighting kit

› Graphic reference

Front view

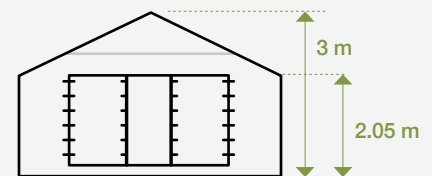

Side view (Window and ventilation)

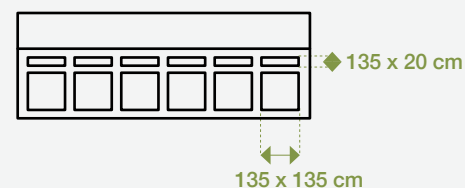

Top view



Huggy 24

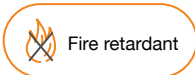

Fire retardant

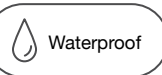

Waterproof



Rot-proof

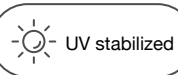

UV stabilized

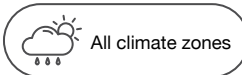

All climate zones



› Key features

- › Waterproof, rotproof and UV-stabilized
- › Lightweight, rectangular and framed tent that can be used for schooling, storage or temporary shelter purposes (comes in three sizes)
- › Outer tent fabric is made of 450 - 455 g/m² PVC coated fabric, natural white
- › Marking and logo customised to your requirements

› Dimensions

Outer tent

Total size	6 x 4 m
Center height	2.80 m
Wall height	1.95 m

Inner tent

Center height	2.30 m
Wall height	1.80 m

› Materials

Outer tent	450 - 455 gsm fire retardant* PVC coated fabric 5,000 mm, natural white
Inner tent	120 gsm Polycotton, natural white
Ground sheet	190 gsm Polyethylene (HDPE), PVC fabric, sewn in bathtub, light grey/natural white
Windows	<ul style="list-style-type: none"> › 6 Windows on long sidewalls 0.85 x 0.85 m with PE stripes reinforcement › 4 Windows on short sidewalls 0.70 x 0.85 m with PE stripes reinforcement

› Graphic reference

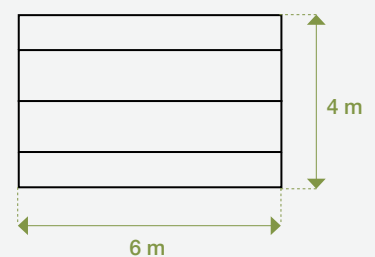
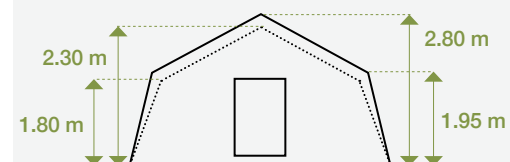

— Outer tent Inner tent

Huggy 42

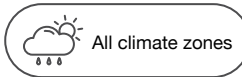
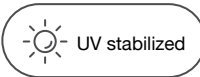
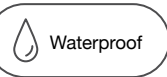

› Key features

- › Waterproof, rotproof and UV-stabilized
- › Lightweight, rectangular and framed tent that can be used for schooling, storage or temporary shelter purposes (comes in three sizes)
- › Outer tent fabric is made of 450 - 455 g/m² PVC coated fabric, natural white
- › Marking and logo customised to your requirements

› Dimensions

Outer tent

Total size	7 x 6 m
Center height	2.95 m
Wall height	2.10 m

Inner tent

Center height	2.40 m
Wall height	1.95 m

› Materials

Outer tent	450 - 455 gsm fire retardant* PVC coated fabric 5,000 mm, natural white
Inner tent	120 gsm Polycotton, natural white
Ground sheet	190 gsm Polyethylene (HDPE), PVC fabric, sewn in bathtub, light grey/natural white
Windows	<ul style="list-style-type: none"> › 8 Windows on long sidewalls 0.90 x 1.10 m with PVC stripes reinforcement › 4 Windows on short sidewalls 0.85 x 1.00 m with PVC stripes reinforcement

› Graphic reference

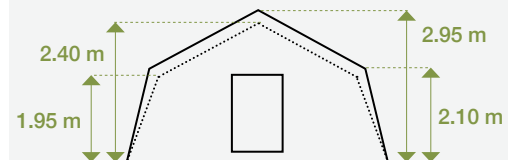

— Outer tent Inner tent

Huggy 72

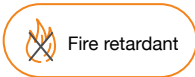

Fire retardant

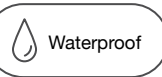

Waterproof

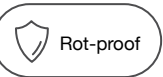

Rot-proof

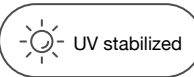

UV stabilized

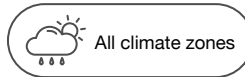

All climate zones



› Key features

- › Waterproof, rotproof and UV-stabilized
- › Lightweight, rectangular and framed tent that can be used for schooling, storage or temporary shelter purposes (comes in three sizes)
- › Outer tent fabric is made of 450 - 455 g/m² PVC coated fabric, natural white
- › Marking and logo customised to your requirements

› Dimensions

Outer tent

Total size	12 x 6 m
Center height	2.95 m
Wall height	2.10 m

Inner tent

Center height	2.40 m
Wall height	1.95 m

› Materials

Outer tent	450 - 455 gsm fire retardant* PVC coated fabric 5,000 mm, natural white
Inner tent	120 gsm Polycotton, natural white
Ground sheet	190 gsm Polyethylene (HDPE), PVC fabric, sewn in bathtub, light grey/natural white
Windows	<ul style="list-style-type: none"> › 12 Windows on long sidewalls 1.05 x 1.10 m with PE stripes reinforcement › 4 Windows on short sidewalls 0.85 x 1.00 m with PE stripes reinforcement

› Graphic reference

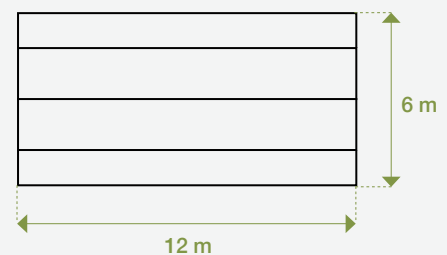
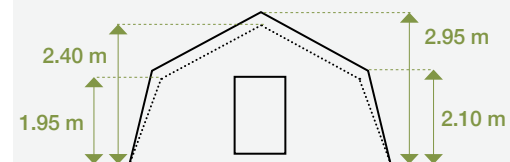

— Outer tent Inner tent

Dispensary Tent

ICRC Standard



Waterproof



Rot-proof



UV stabilized



All climate zones



› Key features

- › 27.5 sqm waterproof tent ideal for medical, educational, office, storage or accommodation use
- › Easy set up with three to four personnel in 30 minutes
- › Especially designed for high resistance to wind, rain and micro-organisms
- › Has triangular ventilation windows, replaceable logo windows, and cable connectors for power supply
- › Optional accessories consist of bath tub ground sheet and shade net, as well as an option for fire retardancy treatment
- › Several tents can be assembled in line with the built-in connection strip
- › Suitable for 8-20 people

› Dimensions

Total size	27 m ²
Length	5.5 m
Width	5.0 m
Wall height	1.8 m

› Materials

Frame	Aluminium frame, all poles with <ul style="list-style-type: none"> › 40 mm diameter and 2 mm thickness › 8 Standing poles, 175 cm, with base plate, › 8 Ridge beam poles, 145 cm › 9 Ridge poles, 171 cm › 12 Connectors
Outer tent roof, wall and door	High quality fabric canvas, 440 gsm, waterproof
Shade net	HDPE with 10 metal sticks

› Graphic reference

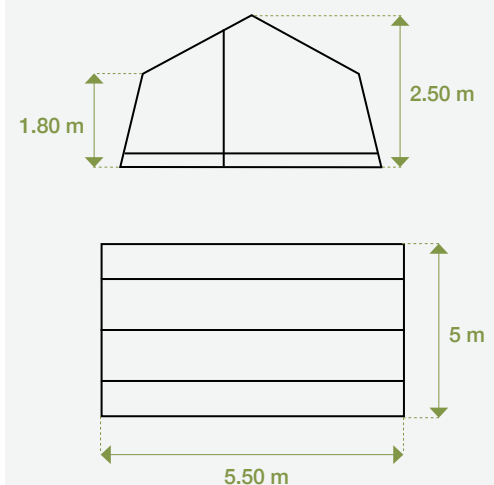

Huggy Pro - Inner Liner

UNICEF standard



Tripple door design



Clean and comfortable



Environmentally friendly



› Key features

- › Designed to create a clean, comfortable, stress-free environment, especially focussing on child-friendly spaces, medical treatment and office/accommodation
- › Highly breathable materials with added ventilation grates in gables and along the top of the side walls
- › In front of the Inner liner is a small vestibule to be used as storage, changing area or waiting room
- › The tripple door design allows costum door configurations, with the centre door fitted with an additional mosquito screen door
- › The gables in front and back are fitted with inlet ducts for externally placed heating or air conditioning units. In the top left and right corners are inlets for power cables
- › Rot and mildew proof, easy to clean and disinfect, resistant to commonly used disinfectants and detergents
- › Environmentally friendly: low energy production process, fully recyclable, safely disposable by burning or burying when recycling is not possible

› Dimensions

Total size	21, 42, 60 m ²
Floor size	5.8 x 3.5 / 5.8 x 7 / 5.8 x 10 m (±2%)
Central height outer tent	2.60 m (±2%)
Wall height outer tent	2.00 m (±2%)
Structure	Suspended with webbing straps from tent frame

Materials

Inner liner	<ul style="list-style-type: none"> › 100% Polyester fabric 120-130 g/m² › Rot-proof Breathable › Fire resistance: CPAI-84 › Colour: Natural White
Groundsheet	<ul style="list-style-type: none"> › PE 190 g/m² approx. FR CPAI-84 › Colour: Light Grey

Huggy Pro - Winter Liner

UNICEF standard

- Insulated flooring
- Warm and comfortable
- Large windows



› Key features

- › Designed to create a warm, comfortable, stress-free environment during winter conditions, especially focussing on child-friendly spaces, medical treatment and office/accommodation
- › The insulation flooring tiles add to the comfort. The insulation flooring tiles can be placed on top of the hard flooring tiles in case the underground is too soft
- › Highly breathable materials with added ventilation grates in gables and along the top of the side walls
- › The winter liner has large windows in the sidewalls to allow daylight in during daytime.
- › The right back corner of the winter liner is prepared to place a burning stove for heating. Heat protecting fibrocement tiles, wall panels and chimney sleeve are included
- › The gables in front and back are fitted with inlet ducts for externally placed heating or air conditioning units. In the top left and right corners are inlets for power cable

› Dimensions

Total size	21, 42, 60 m ²
Floor size	5.8 x 3.5 / 5.8 x 7 / 5.8 x 10 m (±2%)
Central height outer tent	2.60 m (±2%)
Wall height outer tent	2.00 m (±2%)
Structure	Suspended with webbing straps from tent frame

Materials

Winter liner	<ul style="list-style-type: none"> › 100% Polyester non-woven felt fabric 300-350 g/m² › Fire resistance: DIN 4102 B1 › Colour: Natural White
Groundsheet	<ul style="list-style-type: none"> › PE 190 g/m² approx. FR CPAI-84 › Colour: Light Grey
Insulating flooring tiles	PP carpet laminated on 12 mm EVA

The Winter liner kit contains a felt liner, insulated flooring tiles, fibrocement sheet, fire resistant chimney sleeve and wall patches and repair kit

Huggy Pro - Hard Flooring

UNICEF standard

- Easy to handle tiles
- Non-slip surface
- Environmentally friendly

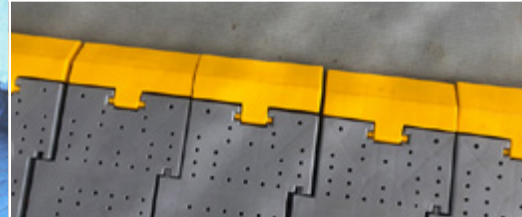
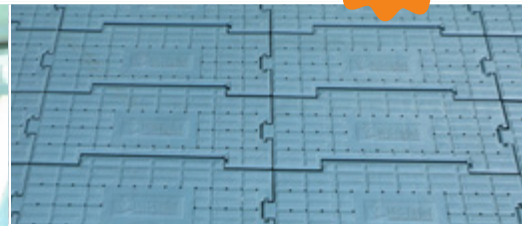

› Key features

- › Modular flooring system for multi-purpose, accommodation, office and warehousing tents
- › High load bearing on on-even and soft grounds
- › The tiles are pre-assemble to easy to handle panels for fast assembly on site
- › Non-slip surface
- › Penetration holes to allow water pass
- › Cable channels allow power cables passing under the floor
- › High visual yellow edge tiles to prevent tripping at entries
- › Environmentally friendly: low energy production process, fully recyclable, safely disposable by burning or burying when recycling is not possible

› Dimensions

Tile size	305 x 102 x 18 mm
Tile per m ²	31.5
Weight m ²	3.84 kg
Load resistance m ²	2,500 kg
Colour	Light grey, bright yellow along the edges
Fire resistance	UL94HB
Packing unit - Master bag with 2 carry-on bags on wooden pallet	2x 378 tiles / 12 m ² - total 24 m ²

Materials

Packing	<ul style="list-style-type: none"> › PE 190 g/m² approx. FR CPAI-84 › Colour: Light Grey
---------	---

100% High impact PolyPropylene

Huggy Pro - Solar Lighting Kit

UNICEF standard

- Easy to assemble/disassemble
- Tube light dimmer controls
- Power saving mode
- Logo customizable



› Key features

- » 30/60/90 Wp solar panel configurations
- » Directly compatible with UNICEF approved High Performance Tents (24/48/72 m²) or similar multi-purpose tents
- » Indoor tube lights has separate dimmer controls
- » Outdoor tube light with on/off control
- » 2A USB charging outlet with current control
- » Has power saving mode that ensures 3 hours of light at low mode
- » User-friendly 5 LED indicators for battery life, and low power mode
- » Single button to control pilot lamp and battery status
- » Built in pilot lamp for easy location in dark
- » Easily replaceable 12.8V/84Wh
- » Expected lifespan is > 3 years, or 1500 cycles (LiFePo4)
- » Colors and logos can be customized as per customer requirements

› Dimensions

Lights	<ul style="list-style-type: none"> » 2x 30 cm tube light 1400 lumens » 1x 15 cm tube light 200 lumens
Run time	<ul style="list-style-type: none"> » Full charge: 6 hours » Emergency mode: 3 hours @ 10% of max. lumens (*Phone charging will reduce lighting run time)
Colour characteristics	CRI 80/5000K
Battery lifespan	More than 3 years or 1,500 cycles
Product colour	Customizable to client requirements

Charging

Solar charging	30 / 60 / 90 WP configurations
Smart phone charging	2x USB ports, USB cable included
Battery	LifePO4 12.8V / 6.6Ah / 84Wh

Huggy Pro - Electrical Lighting Kit

UNICEF standard

 Easy to assemble/disassemble

 Tube light dimmer controls

 Power saving mode

 Logo customizable



› Key features

- › Designed for High Performance Tents (24/48/72 m²), as well as similar type of multipurpose tent
- › Durable LED tubes, constructed from aluminium and plexiglass, fitted with adjustable hanging loops
- › Scalable system, additional lights and sockets can be added
- › Compatible with any shelter with an easy to use unit hanging system
- › Indoor tube lights have individual on/off switches
- › Outdoor bulb light with on/off control
- › 2x 2A USB charging outlet with current control on sockets blocks
- › Main power distribution board with 4 outlets with 16A automatic breaker and on/off switch
- › Expected lifespan is > 5 years

› Dimensions

Lights	<ul style="list-style-type: none"> › 3x 100cm LED Tube Light 2400 lumens, IP44 › 2x LED Bulb Light 900 lumens, IP44
Power distribution	<ul style="list-style-type: none"> › Outlet block, 4x sockets, 2x USB, IP44 › Distribution board, 4x 16A, IP44
Plug & Play cabling	Lights connect to sockets block and main distribution board with plugs and sockets
Power requirement	220V / 50Hz
Performance	Min. 350 Lux on 3m distance from light source
Packing	Durable plastic transport box

Mobile Storage Units

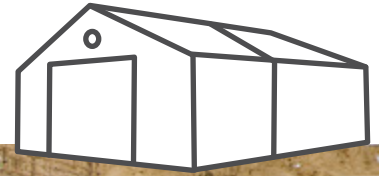

The Rex Hall series mobile storage units (MSU) are the king of our tent range. Rexhall's are reliable large space and modular structures, suitable for all weather conditions, that can be deployed wherever disaster strikes.

Assembly can be done within hours using people power only without the use of mechanical lifting equipment. The units are primarily developed to store food, products, and equipment, but can be adapted to other applications such as hospital, workshop, office or grocery with the use of the wide range of add-ons, including window and door options, flooring, light and electrical supply and internal partitioning.

The Rexhall's are available in 6.5m and 10m width, with a minimum length of 8m. The length can be increased indefinitely with sections of 4m. The most common sizes are 6.5 x 8 m, 10x24 m, 10x32 m.

Rex Hall MSU 6.5 x 8 m

WFP Standard



› Key features

- › Fast set up with three to four people without use of lifting equipment or working on heights
- › Made of durable aluminium box profiles and hot-dipped galvanised hardware, with covers of durable fire retardant and UV resistant translucent PVC fabric and fully HF welded for long life
- › Standard size 6.5 m width by 8 m with large entry doors (sections of or 4 m length can be added)
- › Designed to withstand high wind up to 31 m/s (>110 km/h) and can be used in both hot and cold climates
- › Full range of accessories available, such as solid flooring, lighting kits, pedestrian doors, linking kit, windows and more

› Dimensions

Standard size	6.5 x 8 m
Total living area	52 m ²
Main floor	52 m ²
Centre height	4.0 m
Width	6.50 m
Ridge length	8.00 m
Side wall height	2.50 m

Gable door

Total size	2.90 x 3.00 m
------------	---------------

Modular frame

- › Aluminium box profiles
- › Hot dipped galvanized steel apex, base plates and other steel components

› Graphic reference

Front view

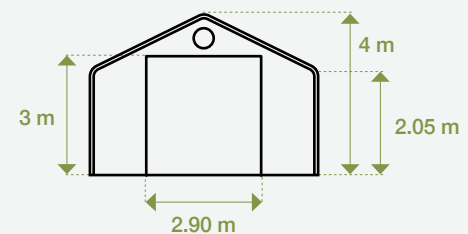

Side view (Windows - Optional)

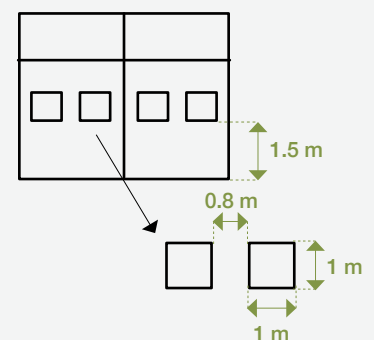

Top view

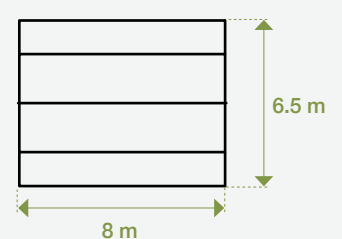



Rex Hall MSU 10.0 x 24 m

Used by ICRC/IFRC/WFP/UNICEF/UNHCR



Fire retardant



Waterproof



Rot-proof



UV stabilized



Logo customizable



› Key features

- › Standard size 10 m width by 24 m length (extra sections of 4 m length can be added) with large entry doors
- › Fast setup with four to six people without use of lifting equipment or working on heights
- › Made of durable aluminum box profiles and hot-dipped galvanized hardware, with covers of durable fire retardant and UV-resistant translucent PVC fabric and fully HF welded for long life
- › Designed to withstand high winds up to 31 m/s (>110 km/h) and can be used in both hot and cold climates
- › Full range of accessories available, such as solid flooring, lighting kits, pedestrian doors, linking kit, windows and more

› Dimensions

Standard size	10 x 24 m
Total useable area	240 m ²
Main floor	240 m ²
Centre height	5.50 m
Width	10.00 m
Ridge length	24.0 m
Side wall height	3.20 m
Gable door	
Total size	4.37 x 4.00 m

Modular frame

- › Aluminium box profiles
- › Hot dipped galvanized steel apex, base plates and other steel components

› Graphic reference

Front view

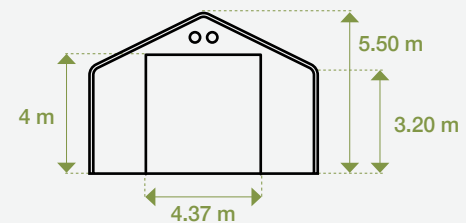

Side view (Windows - Optional)

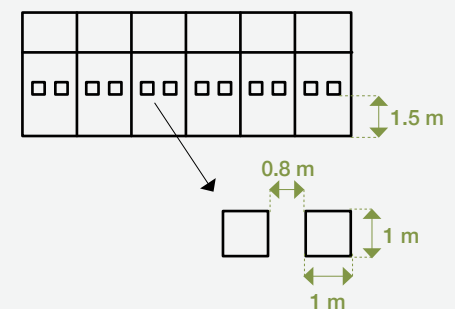

Top view

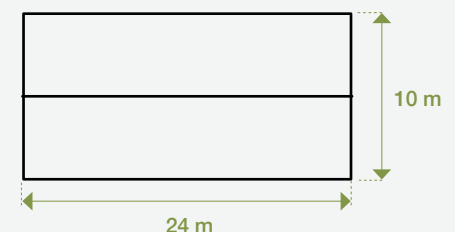



Rex Hall MSU 10.0 x 32 m

Used by ICRC/IFRC/WFP/UNICEF/UNHCR



Fire retardant



Waterproof



Rot-proof



UV stabilized



Logo customizable



› Key features

- › Standard size 10 m width by 32 m length (sections of 4 m length can be added) with large entry doors
- › Fast setup with four to six people without use of lifting equipment or working on heights
- › Made of durable aluminium box profiles & hot-dipped galvanised hardware, with covers of durable fire retardant & UV-resistant translucent PVC fabric & fully HF welded for long life
- › Designed to withstand high wind up to 31 m/s (>110 km/h) & can be used in both hot & cold climates
- › Full range of accessories available, such as solid flooring, lighting kits, pedestrian doors, linking kit, windows and more

› Dimensions

Standard size	10 x 32 m
Total useable area	320 m ²
Main floor	320 m ²
Centre height	5.50 m
Width	10.00 m
Ridge length	32.0 m
Side wall height	3.20 m
Gable door	
Total size	4.37 x 4.00 m
Modular frame	

- › Aluminium box profiles
- › Hot dipped galvanized steel apex, base plates and other steel components

› Graphic reference

Front view

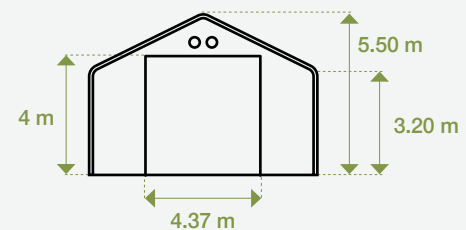

Side view (Windows - Optional)

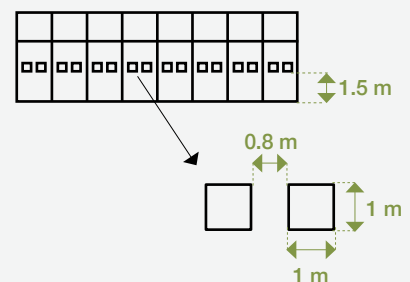

Top view





Rex Hall MSU Add-ons



› LED Lighting kit, 150 lux or 400 lux

An easy to install, plug & play high performance IP65 LED lighting system is available for Rexhall MSU's. The system contains 60W heavy duty LED lights, including hanging brackets, pre-fitted daisy-chain power cables with 16A CEE plugs and a power distribution box with 4x 16A breakers and CEE sockets, packed in a transport box



› Ballast Anchors

Ballast Anchor tubes seal the parameters of the structure to prevent entering of rainwater, dust, sand or snow. The Ballast Anchors can be filled with water through filling openings at the top or filled with sand or stones through the large opening on one of the ends, sealed with a roll closure. The Ballast Anchors are in 3 m length for the tent gables and 8 m length to be placed along the side walls



› Flexible flooring system

PVC coated polyester fabric panels for waterproof floor covering. The flexible flooring creates a waterproof barrier to prevent humidity coming from the underground entering the tent. The flexible flooring can be placed directly on soil or on a concrete foundation platform. It also creates a waterproof barrier on top of under a solid flooring system



› Hard flooring system

Easy to assemble flooring tiles to create a stable and flat surface on soft, soggy, and uneven grounds. Designed to create safe and stable flooring, especially when the tents are used for medical applications, accommodation, or office space. Made of high impact polypropylene. Capable of handling loads up to 2500 kg/m²



› Fire Alarm system

A plug & play fire alarm system connecting wirelessly with the main fire alarm panel. The optical smoke alarm and heat alarm detectors (with built-in sound alarm), alarm controller, RF relay module and manual call points are powered by long-life lithium batteries, while the main fire alarm panel is powered from the grid while fitted with a back-up battery

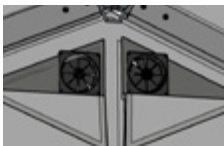

› Mechanical ventilation

Axial flow extractor ventilators installed in pairs in front of the ventilation grade on one gable side. The electrically operated fans extract the air volume inside the MSU minimum one time per hour. Fresh air enters the MSU via the venturi vents in the roof panels as well as the ventilation grades installed in the opposite gable. The fans operate in all climate conditions.



› Windows

The roof panels can be fitted with mesh windows or transparent windows, with or without cover flaps, in 1, 2 or 3-layer systems



› Pedestrian doors

The gables and the side walls of the Rexhall can be fitted with fabric roll-up pedestrian doors with heavy-duty zippers or aluminium hard doors in a frame. The doors are pre-manufactured in special gable or bay covers. Each door come with a special 'no-trip' gable or wall tension bar



› Lateral linking kit

When 2 or more MSU's are installed side-by-side, it is possible to create access between the MSU's using a lateral linking kit. The kit consists of roof panels with 3.5 m wide roll up doors in one or both walls as well as a connecting tunnel module to create a weatherproof connection



› Solar energy systems

Turn-key 2.5 kWh or 5 kWh solar power systems including lithium batteries, 3 kW with built-in MPPT and PV panels with mounting system for safely installation on the MSU roof. Including plug & play cables, fitting and tools

Core Relief Items



Our core relief items such as tarpaulins, blankets, water containers, sleeping mats and winterization kits serve to immediately alleviate the suffering of those in need in the aftermath of every crisis. Our fit-for-purpose aid essentials meet the highest technical standards of UN agencies and International Aid Organizations.

Woven Flexible Tarpaulin

ICRC/IFRC/MSF Standard

- Fire retardant
- Waterproof
- Rot-proof
- UV stabilized
- Logo customizable

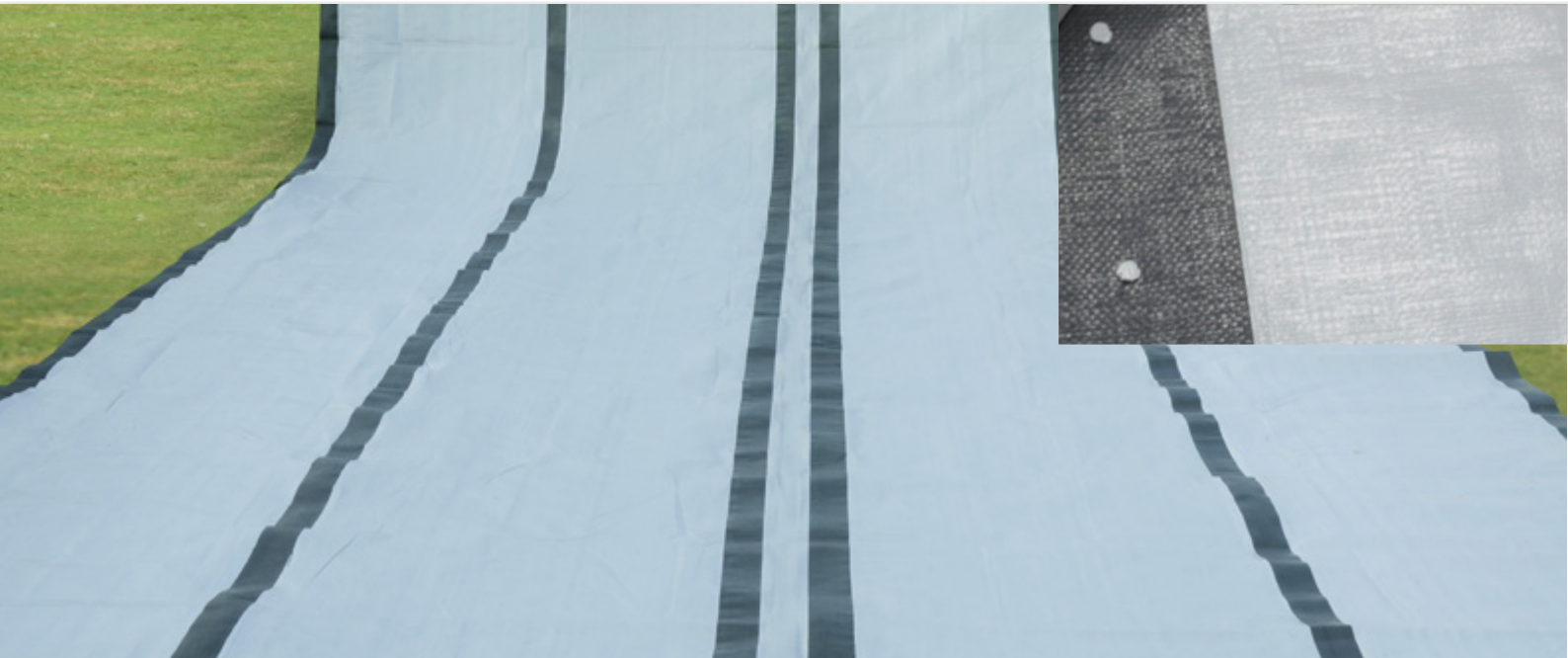

› Key features

- › Fire retardant, waterproof, rotproof and UV-resistant
- › Band reinforced tarpaulin in sheet of 4 x 6 m developed by international research project and designed for long outdoor use in all climates
- › Woven high density polyethylene (HDPE) black fibres fabric coated on both sides with low density polyethylene (LDPE) coating
- › Highly recommended for family shelter protection

› Dimensions

Width and length

Size / Sheet	4 x 6 m ±1%
Size / Roll	4 x 60 m ±1%

Weight

Specific sheet without bands weight	190 g ±20 under ISO 3801 (equivalent to min 170 to 210 gsm max)
Complete sheet with bands weight	Plain sheet specific weight plus 10% additional weight for reinforcement bands under ISO 3801
Total weight	From min 187 to 231 gsm. Specific weight of bands from min 150 to 200 gsm max

› Materials

Sheet	<ul style="list-style-type: none"> › Woven HDPE black fibers fabric, double-side LDPE coating, reinforced with 6 bands of 75 ±3% mm width woven black HDPE fibers fabric and coated outside › Pre-punched 8 mm holes on the 2 side bands at 0.1 m ±10% intervals, positioned in the centre of the bands (only the reinforcement bands are pre-punched, not the tarpaulin itself) › Flame retardant EN13823+A1
Tensile strength	Min 500N, 15-35% elongation in warp and weft in plain sheet under ISO 1421-1

› Graphic reference



Reinforced Plastic Tarpaulin

UNHCR/UNICEF Standard

- Fire retardant
- Waterproof
- Rot-proof
- UV stabilized
- Logo customizable



› Key features

- » Fire retardant, waterproof, rotproof and UV-resistant¹
- » Reinforced plastic tarpaulin in 4 m x 5 m sheet or 4 m x 50 m roll developed by international research project and designed for long outdoor use in all climates
- » Made of woven high density black polyethylene (HDPE) fibers, warp x weft, laminated on both sides with lowdensity polyethylene (LDPE) coating
- » Highly recommended for family shelter protection

› Dimensions

Width and length

Size / Sheet	4 x 5 m ±1%
Size / Roll	4 x 50 m ±1%

› Materials

Sheet / roll	190 gsm ±20 g/m ² woven Polyethylene (HDPE) inner black fibers, warp x weft, laminated on both sides with LDPE coating
Denier	Min 1,000
Tensile strength	Min 600N both directions warp and weft (BS 2576, 50 mm grab test or equivalent)
Tear strength	Min 100N both directions (BS 4303 wing tear or equivalent) or under ISO 4674 (A2)
UV resistance	Max 5% loss of original tensile strength under ISO 1421 after 1500 hours UV under ASTM G53/94 (UVB 313 nm peak)
Welding	Only one is allowed, lengthwise. Min resistance 80% of original tarpaulin tensile strength in the weft under ISO 1421 plus additional procedure
Eyelets	Aluminum reinforcement eyelets or equivalent on 4 sheet sides of single sheets at 100 cm (±5) Centre to Centre, providing very strong fixation points

› Graphic reference

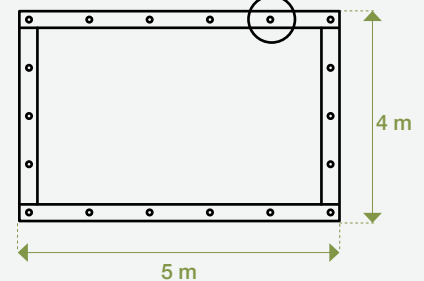

Coverage Kit

- Fire retardant
- Waterproof
- Rot-proof
- UV stabilized
- All climate zones
- Multi-purpose



› Key features

- › Fit-for-purpose shelter kit consisting of two 4 x 6 m plastic sheets, two 24 m long ropes and instructions leaflet
- › Designed for those living in humanitarian settlements setup in the aftermath of natural disasters and humanitarian crises
- › Durable plastic sheeting made from woven high-density polyethylene (HDPE) black fibres fabric, laminated on both sides with low-density polyethylene (LDPE) coating
- › Pre-punched reinforcement bands for easy attachment, such as ropes and nails
- › Designed intending to minimise the impact on the environment
- › Fire retardant, UV stabilized, water, rot and soil resistant
- › Long outdoor use life in all climates
- › Fast and easy setup

› Dimensions

Plastic sheeting

Width	4 m ±1%
Length	6 m minimum
Weight	190 g/m ² ±20 g under ISO 3801 (equivalent to 170 g/m ² minimum to 210 g/m ² maximum)
Additional weight of band (10%)	Total weight with Band from 187 g/m ² minimum and 231 g/m ² maximum

Rope specifications

Diameter	6 mm
Length	2x 24 m
Weight	320 g
Colour	Black
Packaging	Rope coiled to minimize size and height of overall shelter bale

Instructions leaflet specifications

Materials	Printed onto A4 size Tyvek paper
Content	1-page assembly guide sheet with pictorial instructions

› Graphic reference

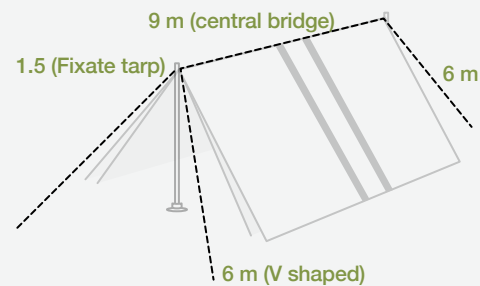
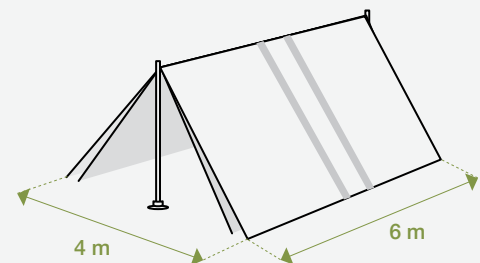

- Cut the ropes into 5 pieces
- Central bridge
 - V-shaped
 - Fixate Tarp



Viva Stove

ICRC/IFRC Standard



Simple and efficient



› Key features

- › Simple yet efficient wood-burning steel stove and heater design adapted to fit a standard family tent and other type of shelter structures that have appropriate chimney opening
- › Works best with our Winterisation Kit

Includes

- › Loading door and air intake control
- › Stand, welded to the stove
- › Outlet to fit with 100 mm pipes.

› Dimensions

Master package size	88 x 30 x 40 cm
Chimney pipe	50 cm long
Chimney outlet	90 mm

› Materials

Stove	Steel, 2 mm thick
Chimney outlet	Steel, 90 mm outlet
Chimney pipes	6 pipes made of galvanised steel, anti-rust
Chimney elbows	2 elbows 20° made of steel, anti-rust
Chimney hood	1 hood made of steel, anti-rust
Disc	1 anti-spark disc made of steel
Brackets	2 brackets for holding pipes to the support made of anti-rust iron sheet
Tripod support	Made of square steel tube, minimum 25 x 1 mm thick, anti-rust paint
Weight	Weight of stove without accessories: 16 kg + 1 kg
Colours	Stove and all parts: steel Colour

› Graphic reference

Chimney pipe

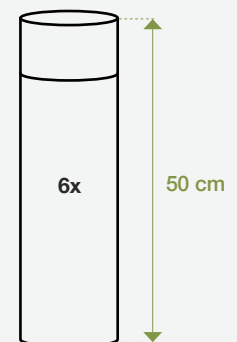



Aquatainer 10L Collapsible

ICRC/IFRC Standard



With spigot



Safe water storage



Easy to carry



Impact-resistant



UV stabilized



› Key features

- › Collapsible 10L water container with handle for carrying and storing clean drinking water
- › With spigot
- › UV-stabilized and impact-resistant
- › Can withstand temperatures between -20°C to +50°C
- › Manufactured food grade low density polyethylene (LDPE) without toxic elements according to EN 1186-3-9 standards

› Dimensions

Capacity	10L minimum
Weight	180 g minimum
Inlet interior diameter	30 mm minimum
Built-in handle	90 x 30 mm diameter minimum
String	1 mm diameter and 120 mm minimum long

› Materials

Container	Manufactured food grade LDPE without toxic elements according to EN 1186-3-9 standard
Operating temperature	Can withstand temperatures between -20°C to +50°C
Impact resistance/ drop test	Impact resistant on hard surface when filled with maximum volume of 10L water. Complete drop test consists of 10 consecutive drops from a 2.00 m height. Test result is expressed as a product ranking according to the number of drops passed without damages or leakage. To be accepted, the water container must resist to a minimum of 3 drops
Colour	Translucent, UV-stabilized



Aquatainer 10L Collapsible

UNHCR Standard

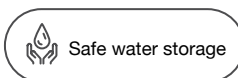

Safe water storage

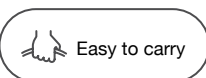

Easy to carry

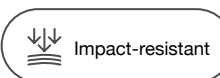

Impact-resistant

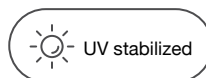

UV stabilized



› Key features

- › Collapsible 10L water container with handle for carrying and storing clean drinking water
- › Without spigot
- › UV-stabilized and impact-resistant
- › Can withstand temperatures between -20°C to +50°C
- › Manufactured food grade low density polyethylene (LDPE) without toxic elements according to EN 1186-3-9 standards

› Dimensions

Capacity	10L minimum
Weight	190 - 230 g
Average thickness	0.60 mm and minimum corner thickness 0.50 mm
Built-in handle	90 x 30 mm diameter minimum
String	1 mm diameter and 120 mm minimum long

› Materials

Container	Manufactured food grade LDPE without toxic elements according to EN 1186-3-9 standard, fitted with built-in carrying handle and removable cap for filling and discharge
Operating temperature	Can withstand temperatures between -20°C to +50°C
Impact resistance/ drop test	Impact resistant on hard surface when filled with maximum volume of 10L water. Complete drop test consists of 10 consecutive drops from a 2.50 m height. Test result is expressed as a product ranking according to the number of drops passed without damages or leakage. To be accepted, the water container must resist to a minimum of 3 drops
Colour	Translucent, UV-stabilized



Aquatainer 20L Collapsible

ICRC/IFRC Standard

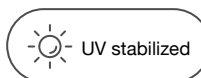
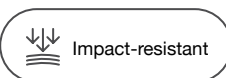
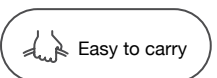
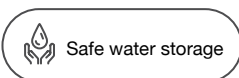
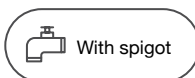

› Key features

- › Collapsible 20L water container with handle for carrying and storing clean drinking water
- › With spigot
- › UV-stabilized and impact-resistant
- › Can withstand temperatures between -20°C to +50°C
- › Manufactured food grade low density polyethylene (LDPE) without toxic elements according to EN 1186-3-9 standards

› Dimensions

Capacity	20L minimum
Weight	270 g minimum
Inlet interior diameter	30 mm minimum
Built-in handle	90 x 30 mm diameter minimum
String	1 mm diameter and 120 mm minimum long

› Materials

Container	Manufactured food grade LDPE without toxic elements according to EN 1186-3-9 standard, fitted with built-in carrying handle and removable cap for filling and discharge
Operating temperature	Can withstand temperatures between -20°C to +50°C
Impact resistance/ drop test	Impact resistant on hard surface when filled with maximum volume of 20L water. Needs to complete testing of 10 consecutive drops from a 2.00 m height, filled with water to its normal maximum capacity. To be accepted, the water container must resist to a minimum of 3 drops
Colour	Translucent, UV-stabilized



Synthetic Sleeping Mat

UNHCR Standard

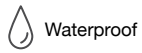

Waterproof



Tearproof



Logo customizable



› Key features

- › Waterproof, tearproof and material trim finish
- › Will last for +12 months of use under hard tropical conditions
- › Suitable for one adult or two children

› Dimensions

Length x Width 1.80 x 0.90 m

Total weight 500 g/m² ±5%

› Materials

Mat Warp: thick tape (PP) or polyester yarn
Weft: 100% virgin (PP) hollow tubes not containing any filler

End width Secured with a woven, bias-binding tape with stitches through the mat fabric OR with a double folded stitched hem.

› Graphic reference

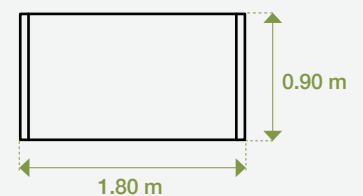



Multipurpose Sleeping Mat

UNHCR Standard



Comfortable



Protection

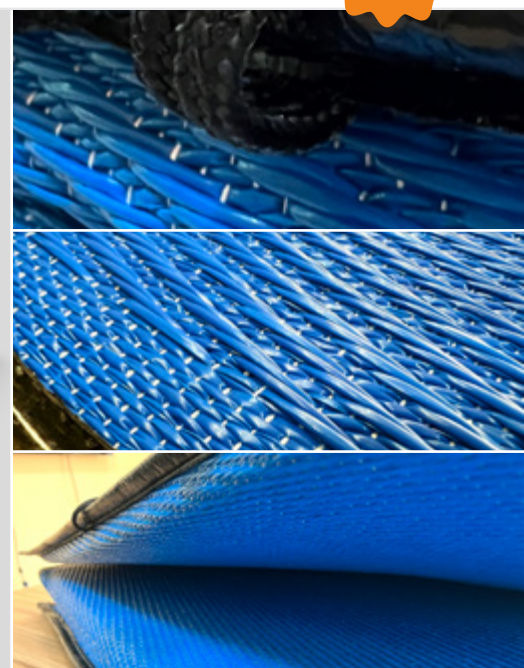

Logo customizable

NEW

› Key features

- › Foam insulation provides comfort and protection against cold and moisture
- › Zig-zag folding makes the mat easy for packing, storage and shipping
- › The mat also turns a great seating bench during daytime

› Dimensions

Mat size	1.8 x 0.9 m $\pm 5\%$
Mat area	1.62 m ² $\pm 5\%$
Weight	0.900 kg/m ² $\pm 10\%$
Bursting strength	700 kPa minimum (ISO 13938)
Tear strength	The edges of the mat should not be tear- able when strongly pulled outside by hand or other similar force

› Materials

Mat	<ul style="list-style-type: none"> › The mats are made from partly recycled polyester yarns and PP straws/tubes. The synthetic yarns and tubes in a tightly woven random structure, using a polyester thread for warping and a min. 500 deniers thick Polypropylene mono-filament straws/tubes for wefting › Sleeping mats are woven in a way to create 4 panels to be filled with 4 pieces of foam (40.5 x 80 x 2 cm $\pm 10\%$) made of EPE (Expanded Polyethylene) fillers › All four sides of the mat are secured with a 5 cm $\pm 10\%$ PE woven bias-binding tape (190 GSM $\pm 10\%$, UNHCR standard for plastic tarpaulin) with stitches through the fabric of the mat › Two 3 mm $\pm 10\%$ ropes each 75 cm $\pm 10\%$ long are fixed on the width side of the mat for binding and folding purposes
Packing	› The sleeping mats are packed in bales of five pieces firmly secured with four strong straps
Pallet details	<ul style="list-style-type: none"> › Fumigation as ISPM-15 standard. Maximum height of the packed pallet is 115 cm › Pallets are shrink-wrapped and strapped. The palletized goods will not exceed the length and width of the pallet

› Graphic reference

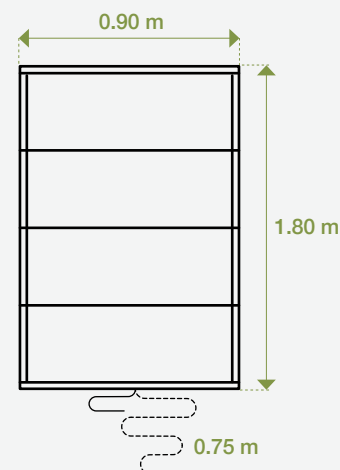

Side view (foam panel)





Viva Thermal Sleeping Mat

ICRC/IFRC Standard

3-layered ribbon

Logo customizable



› Key features

- › Multi-purpose thermal mat that can be used in tents and in other sleeping environments
- › Assembled in 3 layers with heavy-duty ribbon, strongly stitched around the mat's entire perimeter
- › Open at one end to allow filling with local materials that will then transform it into an effective mattress
- › Can be purchased as part of our Viva Winterization Kit.

› Dimensions

Length x Width 1.80 x 0.90 m

Total weight 3.50 kg

› Materials

1st layer - Plastic mat	500 gsm virgin poly-propylene (PP) multifilament, 500 denier in warp PP, hollow tube in weft. Fire retardant* to pass CPAI 84/5. Made in tightly woven twill structure, double thickness (2/1, 3/1, 2/2, 3/2), with minimum 1,000 tubes/meter length. With heavy-duty ribbon, strongly stitched around the entire perimeter
1st layer - Aluminized canvas	Strong synthetic canvas with durable aluminum coating, soft and noiseless. Fire retardant* to pass CPAI 84/5. Stitched together, lengthwise in the centre and crosswise in 3 lines, equally spaced
3rd layer - Fleece blanket	Medim thermal blanket. Fire retardant* to pass CPAI 84/5. Stitched together, lengthwise in the centre and crosswise in 3 lines, equally spaced
Mat opening	At one end, the thermal mat is open to allow access in between the plastic mat and aluminized canvas. This opening closes with a fold (as with a pillow closing system)

› Graphic reference

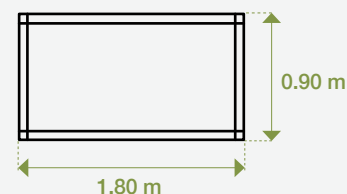

Pura Water Bucket

ICRC/UNHCR Standard



› Key features

- » Non-collapsible, heavy-duty, 14L plastic water bucket with tight-fitting lid, handle and attached clip-on cap
- » UV-resistant and safe for transport and storage of safe drinking water
- » Stackable and easy to carry by hand, available with or without spigot
- » Ideal for family or individual drinking water container

› Dimensions

Capacity	14L minimum
Top diameter	300 mm ±5%
Height	300 mm ±5%
Bottom diameter	240 mm ±5%

› Materials

Container	Manufactured of HDPE and LDPE, durable, UV-resistant, safe for water storage
Top	Reinforced to prevent ovaling
Wall	The walls meet the bottom of the bucket with a curved inside surface to prevent dirt accumulation and facilitate cleaning
Lid	The bucket has a tight-fitting lid of the same material of the bucket with an attached push-on cap
Colour	Bucket: White Cover and handle: Red, green or other Colour upon request

› Graphic reference

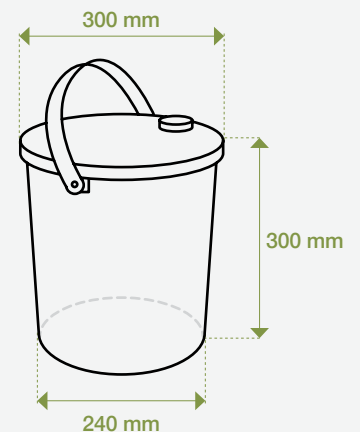



Jerry Bucket

Oxfam Standard



Safe water storage



Easy to carry



Stackable



UV stabilized



With/without spigot



› Key features

- » Improved 14-litre bucket designed to act as a stackable safe water container (rather than as a multipurpose bucket) and to combat the alarming incidence of drinking water contamination
- » An HDPE lid is tightly fitted to the body of the bucket through an improved rim lock design
- » A larger lid opening with a clip-on-cap allows better cleaning and easier filling from hand pumps
- » An optional tap makes taking water from the container simple
- » The curved edges at the base prevents dirt and bacteria accumulation
- » Made from virgin HDPE high density polyethylene (body of the bucket, lid and cap) and virgin LDPE low density polyethylene (handle)
- » Allows easy distribution in large numbers and considerable freight savings
- » Strong and durable quality for a long-life span in tough conditions

› Dimensions

Capacity	14L minimum
Top diameter	300 mm ±5%
Height	300 mm ±5%
Bottom diameter	240 mm ±5%
Component weight	<ul style="list-style-type: none"> » Bucket body: 630 g min. » Lid and cover: 175 g min. » Handle: 30 g min. » Optional tap: 20 g min.
Gross weight	<ul style="list-style-type: none"> » Bucket, lid, cover & handle: 835 g min. » Bucket with tap, lid, cover & handle: 855 g min.
Lid cover opening diameter	100 mm ±5%

› Materials

Bucket Made from food grade virgin HDPE high density polyethylene and virgin LDPE low density polyethylene, according to EN1186-3-9. Manufactured by injection molding process

› Graphic reference

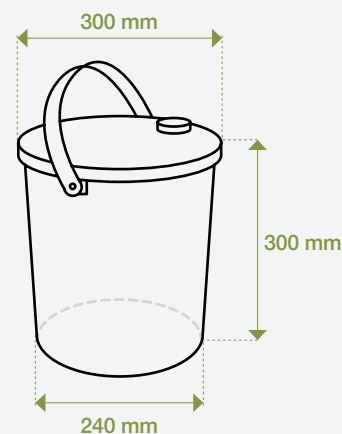



Low Thermal Synthetic Blanket

ICRC/IOM Standard



Mild temperatures



Logo customizable



› Key features

- › Resistant to fire, thermal & air flow
- › Minimum 0.15 Rct (= 1.5 TOG)
- › 1.5 x 2 m low synthetic blankets made of virgin fibres from polyester, knitted and dry raised both sides, C.ISO 1833 on dry weight, 100% virgin polyester
- › Recommended for indoor use, on a bed, in a house with heating facilities

› Dimensions

Total size	1.50 x 2.00 m (Tolerance -1% +3%)
Weight	200 - 400 gsm

› Materials

Blankets	100% virgin fibers from polyester or acrylic, knitted or woven, dry raised both sides, C.ISO 1833 on dry weight, Colour grey
Thickness	ISO 5084, 3.5 mm minimum (1KPa on 2000 mm ²)
Tensile strength	ISO 13934-1: 250N warp and weft minimum
After washing	ISO 13934-1 & ISO 6330: Max 5% warp and weft after 3 consecutive machine washes at 30°C and one flat drying
Shrinkage	ISO 6330: Max 5% warp and weft after 3 consecutive machine washes at 30°C and one flat drying
Weight loss after washing	Max 5% after 3 consecutive machine washes at 30°C and one flat drying
Thermal resistance	ISO 11092: TOG 1.5 (or Rct 0.15 m ² K/W) minimum, rounded to the nearest 0.01, passed on samples picked from compressed bales. After opening of the bale, the blanket shall be dry tumbled in a dryer for 15 minutes (without any other load), at a temperature of less than 30°C and at least 24 hours by flat lying
Air flow resistance	ISO 9237 under 100Pa pressure drop: Max 1500 L/m ² /s

› Graphic reference

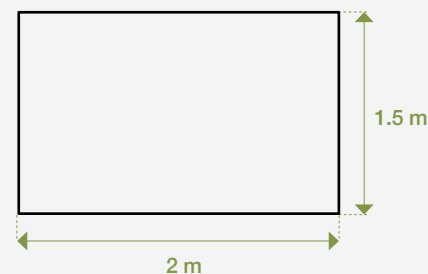

Medium Thermal Synthetic Blanket

ICRC/IOM Standard

 Mild/cold temperatures

 Logo customizable

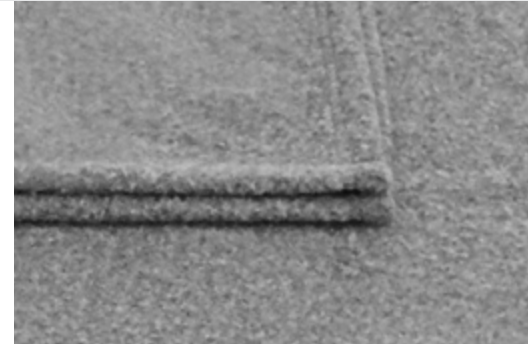

› Key features

- › Resistant to fire, thermal & air flow
- › Minimum 0.25 Rct (= 2.5 TOG)
- › 1.5 x 2 m medium synthetic blankets made of virgin fibres from polyester, knitted & dry raised both sides, C.ISO 1833 on dry weight, 100% virgin polyester
- › Recommended in mildly cold temperatures

› Dimensions

Total size	1.50 x 2.00 m (Tolerance -1% +3%)
Weight	400 - 700 gsm

› Materials

Blankets	100% virgin fibers from polyester, knitted & dry raised on both sides, C.ISO 1833 on dry weight, grey
Thickness	ISO 5084, 6.5 mm minimum (1KPa on 2000 mm ²)
Tensile strength	ISO 13934-1: 250N warp and weft minimum
After washing	ISO 13934-1 & ISO 6330: Max 5% warp and weft after 3 consecutive machine washes at 30°C and one flat drying
Shrinkage	ISO 6330: Max 5% warp and weft after 3 consecutive machine washes at 30°C & one flat drying
Weight loss after washing	Max 5% after 3 consecutive machine washes at 30°C & one flat drying
Thermal resistance	ISO 5085-1: TOG 2.5 (or Rct 0.25 m ² K/W) minimum, rounded to the nearest 0.1, passed on samples picked from compressed bales after 3 consecutive machine washes at 30°C & one flat drying
Air flow resistance	ISO 9237 under 100Pa pressure drop: Max 1000L/m ² /s

› Graphic reference

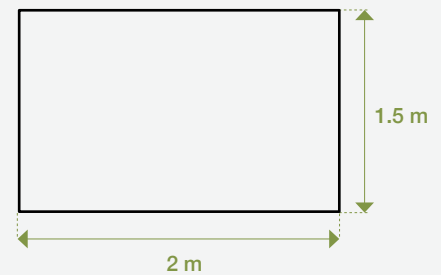

Medium Thermal Synthetic Blanket

UNHCR/UNICEF Standard

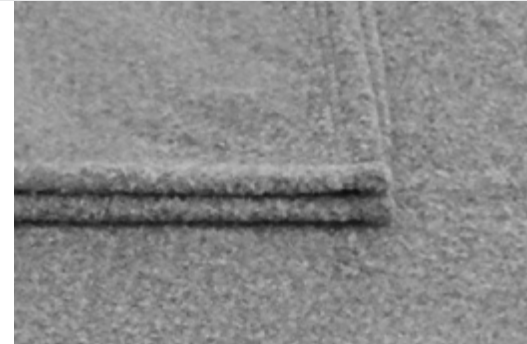
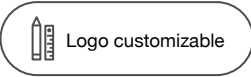
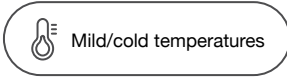

› Key features

- › Resistant to fire, thermal and air flow
- › Minimum 2.5 TOG for outdoor use and indoor use without artificial heat
- › 1.5 x 2 m medium synthetic blankets made of virgin fibers from polyester, knitted and dry raised both sides, ISO C1833 on dry weight, 100% virgin polyester
- › Recommended in mildly cold temperatures

› Dimensions

Total size	1.50 x 2.00 m (Tolerance -1% +3%)
Weight	400 - 700 gsm

› Materials

Blankets	100% virgin fibers from polyester, knitted and dry raised on both sides, ISO C1833 on dry weight, grey
Thickness	ISO 5084, 6.5 mm minimum (1KPa on 2000 mm ²)
Tensile strength	ISO 13934-1: 250N warp and weft minimum
After washing	ISO 13934-1 and ISO 6330: Max 5% warp and weft after 3 consecutive machine washes at 30°C and one flat drying
Shrinkage	ISO 6330: Max 5% warp and weft after 3 consecutive machine washes at 30°C and one flat drying
Weight loss after washing	Max 5% after 3 consecutive machine washes at 30°C and one flat drying
Thermal resistance	ISO 5085-1: TOG 2.5 (or 0.25m ² K/W) minimum, rounded to the nearest 0.1, passed on samples picked from compressed bales after 3 consecutive machine washes at 30°C and one flat drying
Air flow resistance	ISO 9237 under 100Pa pressure drop: Max 1000L/m ² /s

› Graphic reference

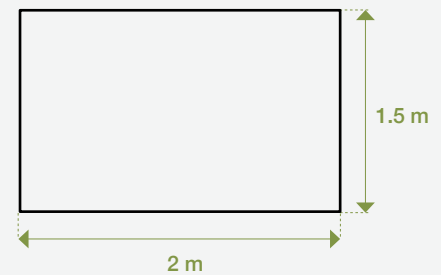



High Thermal Synthetic Blanket

ICRC/IOM Standard



Cold temperatures



Logo customizable

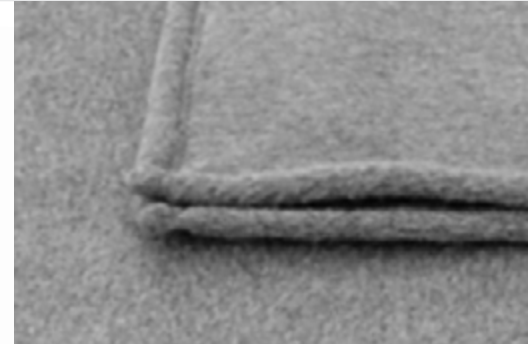

› Key features

- › Resistant to fire, thermal and air flow
- › Min 0.40 Rct (= 4.0 TOG)
- › 1.5 x 2 m high synthetic blankets made of virgin fibers from polyester, knitted & dry raised on both sides, C.ISO 1833 on dry weight, 100% virgin polyester
- › Recommended for cold climate/temperatures

› Dimensions

Total size	1.50 x 2.00 m (Tolerance -1% +3%)
Weight	500 - 1000 gsm

› Materials

Blankets	100% virgin fibers from polyester, knitted & dry raised on both sides, C.ISO 1833 on dry weight, grey
Thickness	ISO 5084, 9.5 mm minimum (1KPa on 2000 mm ²)
Tensile strength	ISO 13934-1, 250N warp and weft minimum
After washing	ISO 13934-1 & ISO 6330: Max 5% warp and weft after 3 consecutive machine washes at 30°C and one flat drying
Shrinkage	Max ISO 6330: Max 5% warp and weft after 3 consecutive machine washing at 30°C and one flat drying
Weight loss after washing	Max 5% after 3 consecutive machine washing at 30°C and one flat drying
Thermal resistance	ISO 5085-1: TOG 4 (or Rct 0.4 m ² K/W) minimum, rounded to the nearest 0.1, passed on samples picked from com after 3 consecutive machine washes at 30°C and one flat drying pressed bales
Air flow resistance	ISO 9237 under 100Pa pressure drop: Maximum 1000L/m ² /s

› Graphic reference

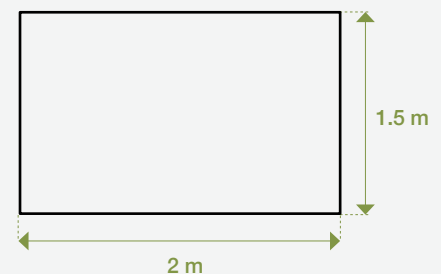



High Thermal Synthetic Blanket

UNHCR/UNICEF Standard



Cold temperatures



Logo customizable

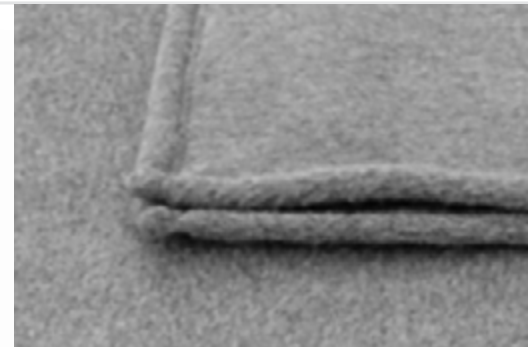

› Key features

- › Resistant to fire, thermal and air flow
- › Minimum 4.0 TOG for indoor use and cold climates
- › 1.5 x 2 m high synthetic blankets made of virgin fibers from polyester, knitted & dry raised on both sides, ISO 1833 on dry weight, 100% virgin polyester

› Dimensions

Total size	1.50 x 2.00 m (Tolerance -1% +3%)
Weight	500 - 1000 gsm

› Materials

Blankets	100% virgin fibers from polyester, knitted & dry raised on both sides, ISO 1833 on dry weight, grey
Thickness	ISO 5084, 9.5 mm minimum (1KPa on 2000 mm ²)
Tensile strength	ISO 13934-1, 250N warp & weft minimum
After washing	ISO 13934-1 & ISO 6330: Max 5% warp & weft after 3 consecutive machine washes at 30°C and one flat drying
Shrinkage	Max ISO 6330: Max 5% warp & weft after 3 consecutive machine washing at 30°C and one flat drying
Weight loss after washing	Max 5% after 3 consecutive machine washing at 30°C and one flat drying
Thermal resistance	ISO 5085-1: TOG 4 (or 0.4m ² K/W) minimum, rounded to the nearest 0.1, passed on samples picked from compressed bales after 3 consecutive machine washes at 30°C and one flat drying
Air flow resistance	ISO 9237 under 100Pa pressure drop: Maximum 1000L/m ² /s

› Graphic reference

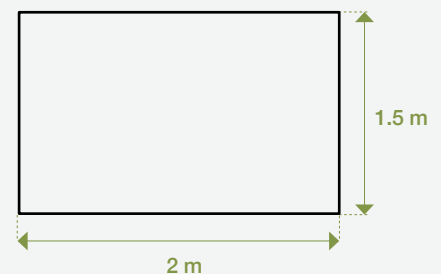





NRS Relief FZCO
PO Box 18168

Jebel Ali Free Zone (JAFZA)
Dubai, United Arab Emirates

General queries
info@nrsrelief.com

Sales queries
bdm@nrsrelief.com



*To visit our website,
Click [here](#) or scan
the code*